

# FANUC Robot R-2000iC



## Features

The FANUC Robot R-2000iC is an intelligent robot based on FANUC's years of experience and renowned technology. This high performance intelligent robot with outstanding reliability and cost performance will support your needs in various applications, such as spot welding, material handling and assembly.

- Weight reduction of the mechanical unit and compact robot
- The rigid yet lightweight arm and the advanced motion control technology achieve significantly improved motion performance, allowing for higher productivity.
- Extensive options are available for various processes, including the spot welding solution arm.
- The R-30iB/R-30iB Plus controller provides energy and floor space savings with its energy regeneration option and compact cabinet.
- Available with the various intelligent features such as the Learning Robot, Bin Picking, Force Sensing and Visual Line Tracking.

## Application Example



High Speed Spot Welding

## Lineup

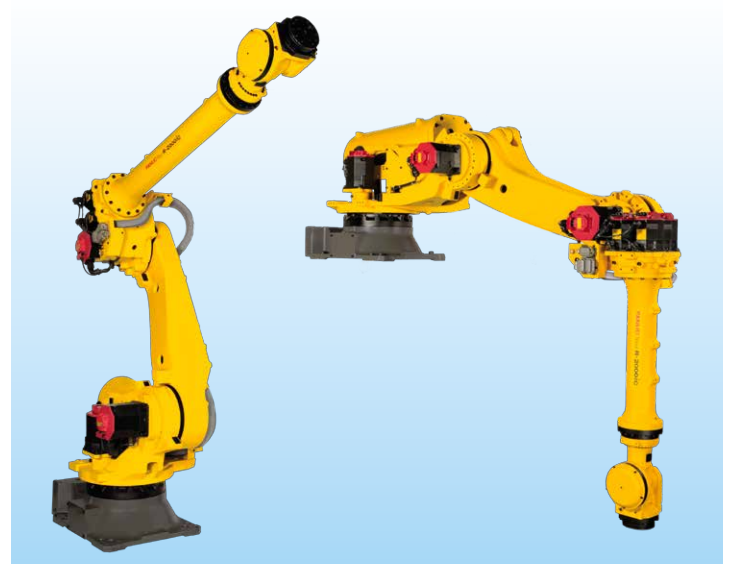

Long Reach/Rack Mount

## Operating space

# R-2000iC/240F,/210F,/165F,/125L

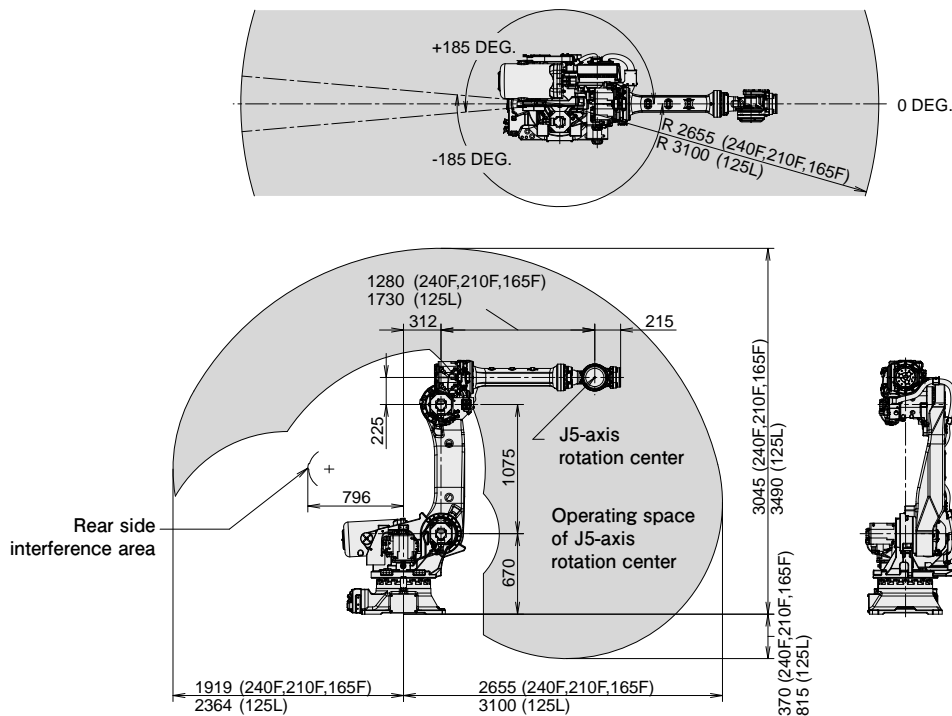

## Specifications

Model		R-2000iC/240F	R-2000iC/210F	R-2000iC/165F	R-2000iC/125L	
Type		Articulated Type				
Controlled axes		6 axes (J1, J2, J3, J4, J5, J6)				
Reach		2655 mm			3100 mm	
Installation		Floor				
Motion range (Maximum speed) Note 1)	J1 axis rotation	370°(115°/s) 6.46 rad (2.01 rad/s)	370°(120°/s) 6.46 rad (2.09 rad/s)	370°(130°/s) 6.46 rad (2.27 rad/s)		
	J2 axis rotation	136°(90°/s) 2.37 rad (1.57 rad/s)	136°(105°/s) 2.37 rad (1.83 rad/s)	136°(115°/s) 2.37 rad (2.01 rad/s)		
	J3 axis rotation	312°(105°/s) 5.45 rad (1.83 rad/s)	312°(110°/s) 5.45 rad (1.92 rad/s)	312°(125°/s) 5.45 rad (2.18 rad/s)	301°(125°/s) 5.25 rad (2.18 rad/s)	
	J4 axis wrist rotation	720°(130°/s) 12.57 rad (2.27 rad/s)	720°(140°/s) 12.57 rad (2.44 rad/s)	720°(180°/s) 12.57 rad (3.14 rad/s)		
	J5 axis wrist swing	250°(130°/s) 4.36 rad (2.27 rad/s)	250°(140°/s) 4.36 rad (2.44 rad/s)	250°(180°/s) 4.36 rad (3.14 rad/s)		
	J6 axis wrist rotation	720°(210°/s) 12.57 rad (3.67 rad/s)	720°(220°/s) 12.57 rad (3.84 rad/s)	720°(260°/s) 12.57 rad (4.54 rad/s)		
	Max. load capacity at wrist		240 kg	210 kg	165 kg	125 kg
Max. load capacity at J2 base		550 kg		550 kg	550 kg	
Max. load capacity on J3 arm		25 kg (A)	25 kg (A)	25 kg (A)	25 kg (A)	
Max. load capacity on J3 casing		50 kg (B)	50 kg (B)	50 kg (B)	40 kg (B)	
		(A) + (B) ≤ 50 kg		(A) + (B) ≤ 50 kg		
Allowable load moment at wrist	J4 axis	1400 N·m 143 kgf·m	1360 N·m 139 kgf·m	940 N·m 96 kgf·m	710 N·m 72 kgf·m	
	J5 axis	1400 N·m 143 kgf·m	1360 N·m 139 kgf·m	940 N·m 96 kgf·m	710 N·m 72 kgf·m	
	J6 axis	800 N·m 82 kgf·m	735 N·m 75 kgf·m	490 N·m 50 kgf·m	355 N·m 36 kgf·m	
Allowable load inertia at wrist	J4 axis	250 kg·m <sup>2</sup> 2551 kgf·cm·s <sup>2</sup>	147 kg·m <sup>2</sup> 1500 kgf·cm·s <sup>2</sup>	89 kg·m <sup>2</sup> 908 kgf·cm·s <sup>2</sup>	72 kg·m <sup>2</sup> 735 kgf·cm·s <sup>2</sup>	
	J5 axis	250 kg·m <sup>2</sup> 2551 kgf·cm·s <sup>2</sup>	147 kg·m <sup>2</sup> 1500 kgf·cm·s <sup>2</sup>	89 kg·m <sup>2</sup> 908 kgf·cm·s <sup>2</sup>	72 kg·m <sup>2</sup> 735 kgf·cm·s <sup>2</sup>	
	J6 axis	200 kg·m <sup>2</sup> 2041 kgf·cm·s <sup>2</sup>	82 kg·m <sup>2</sup> 837 kgf·cm·s <sup>2</sup>	46 kg·m <sup>2</sup> 469 kgf·cm·s <sup>2</sup>	40 kg·m <sup>2</sup> 408 kgf·cm·s <sup>2</sup>	
Drive method		Electric servo drive by AC servo motor				
Repeatability Note 2)		± 0.05 mm				
Mass Note 3)		1090 kg	1090 kg	1090 kg	1115 kg	
Installation environment		Ambient temperature : 0 to 45°C Ambient humidity : Normally 75%RH or less (No dew, nor frost allowed) Short term Max. 95%RH or less (within one month) Vibration acceleration : 4.9m/s <sup>2</sup> (0.5G) or less				

Note 1) During short distance motions, the axis speed may not reach the maximum value stated.

Note 2) Compliant with ISO 9283.

Note 3) Without controller.

# Operating space

## R-2000iC/270F,/210L

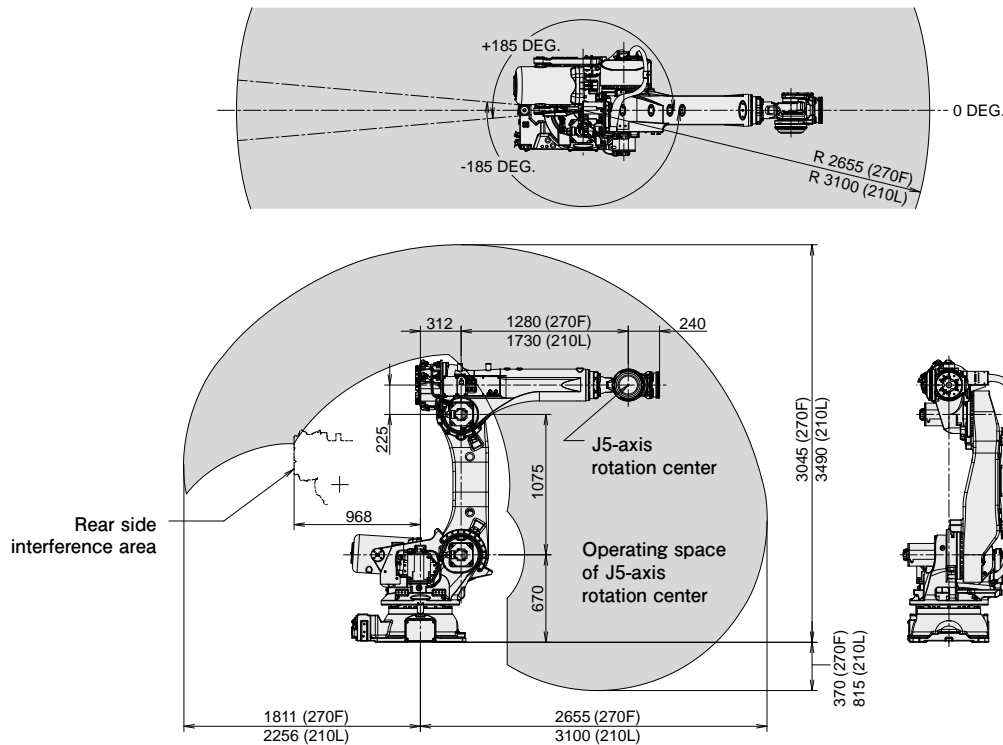

## Specifications

Model		R-2000iC/270F		R-2000iC/210L		
Type		Articulated Type				
Controlled axes		6 axes (J1, J2, J3, J4, J5, J6)				
Reach		2655 mm		3100 mm		
Installation		Floor				
Motion range (Maximum speed) Note 1)	J1 axis rotation	370°(105°/s) 6.46 rad (1.83 rad/s)		301°( 85°/s) 5.25 rad (1.48 rad/s)		
	J2 axis rotation	136°( 90°/s) 2.37 rad (1.57 rad/s)				
	J3 axis rotation	312°( 85°/s)	5.45 rad (1.48 rad/s)		301°( 85°/s)	5.25 rad (1.48 rad/s)
	J4 axis wrist rotation	720°(120°/s) 12.57 rad (2.09 rad/s)		720°(200°/s) 12.57 rad (3.49 rad/s)		
	J5 axis wrist swing	250°(120°/s) 4.36 rad (2.09 rad/s)				
	J6 axis wrist rotation	720°(200°/s) 12.57 rad (3.49 rad/s)				
Max. load capacity at wrist		270 kg		210 kg		
Max. load capacity at J2 base		550 kg				
Max. load capacity on J3 arm		40 kg (A)	(A)×5/4+(B) ≤ 50 kg	20 kg (A)	(A)×5/2+(B) ≤ 50 kg	
Max. load capacity on J3 casing		50 kg (B)		50 kg (B)		
Allowable load moment at wrist	J4 axis	1730 N·m 177 kgf·m		1700 N·m 173 kgf·m		
	J5 axis	1730 N·m 177 kgf·m		1700 N·m 173 kgf·m		
	J6 axis	900 N·m 92 kgf·m		900 N·m 92 kgf·m		
Allowable load inertia at wrist	J4 axis	320 kg·m <sup>2</sup> 3265 kgf·cm·s <sup>2</sup>		320 kg·m <sup>2</sup> 3265 kgf·cm·s <sup>2</sup>		
	J5 axis	320 kg·m <sup>2</sup> 3265 kgf·cm·s <sup>2</sup>		320 kg·m <sup>2</sup> 3265 kgf·cm·s <sup>2</sup>		
	J6 axis	230 kg·m <sup>2</sup> 2347 kgf·cm·s <sup>2</sup>		230 kg·m <sup>2</sup> 2347 kgf·cm·s <sup>2</sup>		
Drive method		Electric servo drive by AC servo motor				
Repeatability Note 2)		± 0.05 mm				
Mass Note 3)		1320 kg		1350 kg		
Installation environment		Ambient temperature : 0 to 45°C Ambient humidity : Normally 75%RH or less (No dew, nor frost allowed) Short term Max. 95%RH or less (within one month) Vibration acceleration : 4.9 m/s <sup>2</sup> (0.5G) or less				

Note 1) During short distance motions, the axis speed may not reach the maximum value stated.

Note 2) Compliant with ISO 9283.

Note 3) Without controller.

## Operating space

# R-2000iC/270R,/210R,/165R,/100P

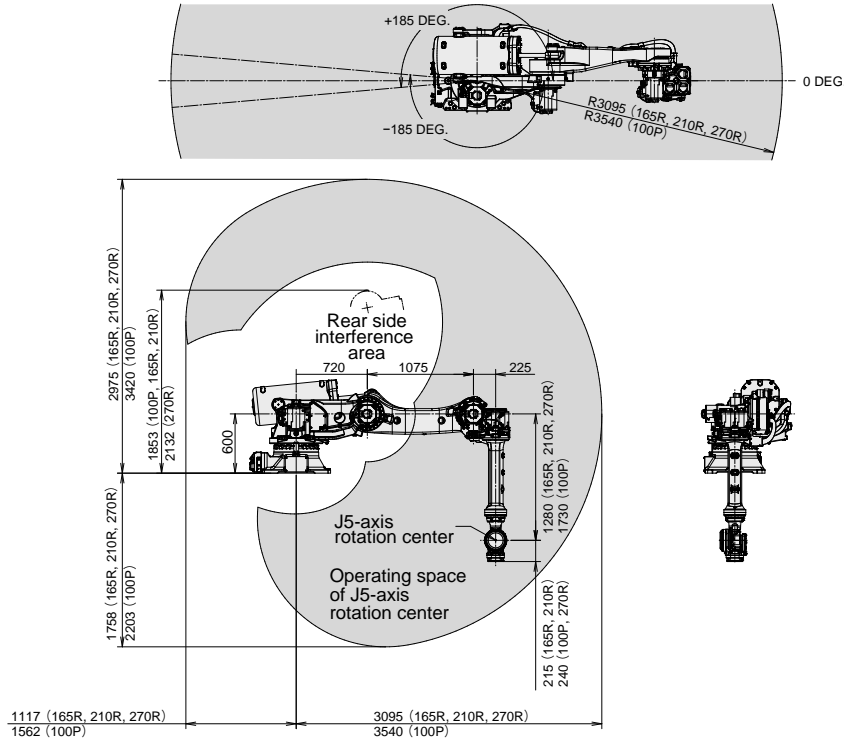

## Specifications

Model		R-2000iC/270R	R-2000iC/210R	R-2000iC/165R	R-2000iC/100P	
Type		Articulated Type				
Controlled axes		6 axes (J1, J2, J3, J4, J5, J6)				
Reach		3095 mm			3540 mm	
Installation		Rack mount				
Motion range (Maximum speed) Note 1)	J1 axis rotation	370°(105°/s) 6.46 rad (1.83 rad/s)	370°(105°/s) 6.46 rad (1.83 rad/s)	370°(115°/s) 6.46 rad (2.01 rad/s)	370°(120°/s) 6.46 rad (2.09 rad/s)	
	J2 axis rotation	200°(85°/s) 3.49 rad (1.48 rad/s)	200°(100°/s) 3.49 rad (1.75 rad/s)	200°(110°/s) 3.49 rad (1.92 rad/s)	200°(100°/s) 3.49 rad (1.75 rad/s)	
	J3 axis rotation	375°(85°/s) 6.54 rad (1.48 rad/s)	375°(110°/s) 6.54 rad (1.92 rad/s)	375°(125°/s) 6.54 rad (2.18 rad/s)	375°(115°/s) 6.54 rad (2.01 rad/s)	
	J4 axis wrist rotation	720°(120°/s) 12.57 rad (2.09 rad/s)	720°(140°/s) 12.57 rad (2.44 rad/s)	720°(180°/s) 12.57 rad (3.14 rad/s)	720°(140°/s) 12.57 rad (2.44 rad/s)	
	J5 axis wrist swing	250°(120°/s) 4.36 rad (2.09 rad/s)	250°(140°/s) 4.36 rad (2.44 rad/s)	250°(180°/s) 4.36 rad (3.14 rad/s)	250°(140°/s) 4.36 rad (2.44 rad/s)	
	J6 axis wrist rotation	720°(200°/s) 12.57 rad (3.49 rad/s)	720°(220°/s) 12.57 rad (3.84 rad/s)	720°(260°/s) 12.57 rad (4.54 rad/s)	720°(210°/s) 12.57 rad (3.66 rad/s)	
	Max. load capacity at wrist	270 kg		210 kg	165 kg	100 kg
Max. load capacity at J2 base	550 kg		550 kg	550 kg	550 kg	
Max. load capacity on J3 arm	30 kg (A)	(A)×4/3+(B) ≤ 40 kg	30 kg (A)	(A)×4/3+(B) ≤ 40 kg	25 kg (A)	(A)×2+(B) ≤ 50kg
Max. load capacity on J3 casing	40 kg (B)	40 kg	40 kg (B)	40 kg	50 kg (B)	50kg
Allowable load moment at wrist	J4 axis	1730 N·m 177 kgf·m	1360 N·m 139 kgf·m	940 N·m 96 kgf·m	1000 N·m 102 kgf·m	
	J5 axis	1730 N·m 177 kgf·m	1360 N·m 139 kgf·m	940 N·m 96 kgf·m	1000 N·m 102 kgf·m	
	J6 axis	900 N·m 92 kgf·m	735 N·m 75 kgf·m	490 N·m 50 kgf·m	706 N·m 72 kgf·m	
Allowable load inertia at wrist	J4 axis	320 kg·m <sup>2</sup> 3265 kgf·cm·s <sup>2</sup>	147 kg·m <sup>2</sup> 1500 kgf·cm·s <sup>2</sup>	89 kg·m <sup>2</sup> 908 kgf·cm·s <sup>2</sup>	227 kg·m <sup>2</sup> 2316 kgf·cm·s <sup>2</sup>	
	J5 axis	320 kg·m <sup>2</sup> 3265 kgf·cm·s <sup>2</sup>	147 kg·m <sup>2</sup> 1500 kgf·cm·s <sup>2</sup>	89 kg·m <sup>2</sup> 908 kgf·cm·s <sup>2</sup>	227 kg·m <sup>2</sup> 2316 kgf·cm·s <sup>2</sup>	
	J6 axis	230 kg·m <sup>2</sup> 2347 kgf·cm·s <sup>2</sup>	82 kg·m <sup>2</sup> 837 kgf·cm·s <sup>2</sup>	46 kg·m <sup>2</sup> 469 kgf·cm·s <sup>2</sup>	196 kg·m <sup>2</sup> 2000 kgf·cm·s <sup>2</sup>	
Drive method	Electric servo drive by AC servo motor					
Repeatability Note 2)	± 0.05 mm					
Mass Note 3)	1590 kg	1370 kg	1370 kg	1470 kg		
Installation environment	Ambient temperature : 0 to 45°C Ambient humidity : Normally 75 %RH or less (No dew, nor frost allowed) Short term Max. 95 %RH or less (within one month) Vibration acceleration : 4.9 m/s <sup>2</sup> (0.5G) or less					

Note 1) During short distance motions, the axis speed may not reach the maximum value stated.

Note 2) Compliant with ISO 9283.

Note 3) Without controller.

## Operating space

### R-2000iC/220U

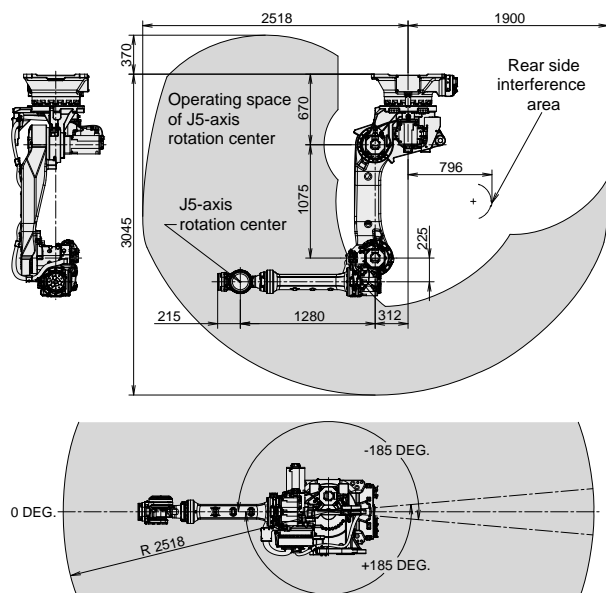

### R-2000iC/190U

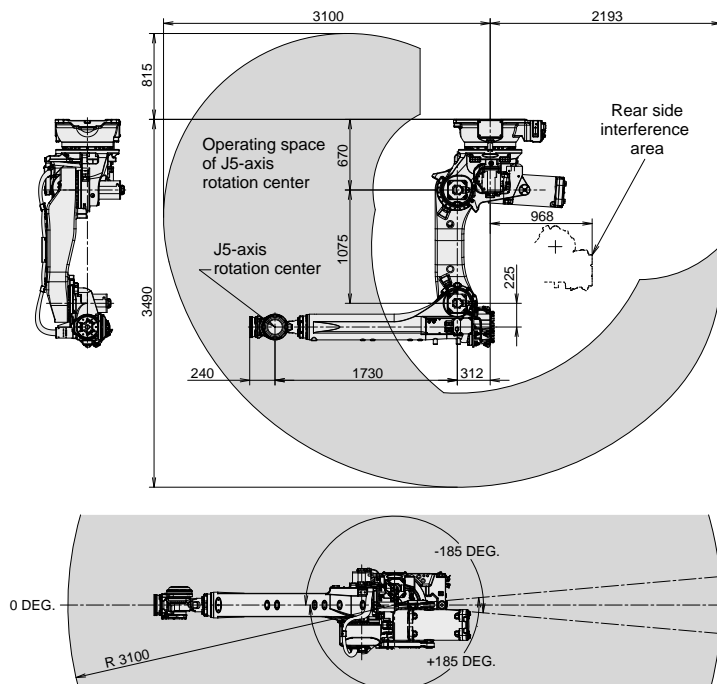

## Specifications

Model		R-2000iC/220U		R-2000iC/190U	
Type		Articulated Type			
Controlled axes		6 axes (J1, J2, J3, J4, J5, J6)			
Reach		2518 mm		3100 mm	
Installation		Upside-down			
Motion range (Maximum speed) Note 1)	J1 axis rotation	370°(120°/s)	6.46 rad (2.09 rad/s)	370°(105°/s)	6.46 rad (1.83 rad/s)
	J2 axis rotation	136°( 85°/s)	2.37 rad (1.48 rad/s)	136°( 85°/s)	2.37 rad (1.48 rad/s)
	J3 axis rotation	312°(110°/s)	5.45 rad (1.92 rad/s)	301°( 85°/s)	5.25 rad (1.48 rad/s)
	J4 axis wrist rotation	720°(140°/s)	12.57 rad (2.44 rad/s)	720°(120°/s)	12.57 rad (2.09 rad/s)
	J5 axis wrist swing	250°(140°/s)	4.36 rad (2.44 rad/s)	250°(120°/s)	4.36 rad (2.09 rad/s)
	J6 axis wrist rotation	720°(220°/s)	12.57 rad (3.84 rad/s)	720°(200°/s)	12.57 rad (3.49 rad/s)
Max. load capacity at wrist		220 kg		190 kg	
Max. load capacity at J2 base		-			
Max. load capacity on J3 arm		25 kg (A)	(A)×6/5 + (B) ≤ 30kg	20 kg (A)	(A)×5/2 + (B) ≤ 50kg
Max. load capacity on J3 casing		30 kg (B)		50 kg (B)	
Allowable load moment at wrist	J4 axis	1360 N·m 139 kgf·m		1700 N·m 173 kgf·m	
	J5 axis	1360 N·m 139 kgf·m		1700 N·m 173 kgf·m	
	J6 axis	735 N·m 75 kgf·m		900 N·m 92 kgf·m	
Allowable load inertia at wrist	J4 axis	147 kg·m <sup>2</sup> 1500 kgf·cm·s <sup>2</sup>		320 kg·m <sup>2</sup> 3265 kgf·cm·s <sup>2</sup>	
	J5 axis	147 kg·m <sup>2</sup> 1500 kgf·cm·s <sup>2</sup>		320 kg·m <sup>2</sup> 3265 kgf·cm·s <sup>2</sup>	
	J6 axis	82 kg·m <sup>2</sup> 837 kgf·cm·s <sup>2</sup>		230 kg·m <sup>2</sup> 2347 kgf·cm·s <sup>2</sup>	
Drive method		Electric servo drive by AC servo motor			
Repeatability Note 2)		± 0.05 mm			
Mass Note 3)		1020 kg		1400 kg	
Installation environment		Ambient temperature : 0 to 45°C Ambient humidity : Normally 75 %RH or less (No dew, nor frost allowed) Short term Max. 95 %RH or less (within one month) Vibration acceleration : 4.9 m/s <sup>2</sup> (0.5G) or less			

Note 1) During short distance motions, the axis speed may not reach the maximum value stated.

Note 2) Compliant with ISO 9283.

Note 3) Without controller.

## Operating space

# R-2000iC/210WE

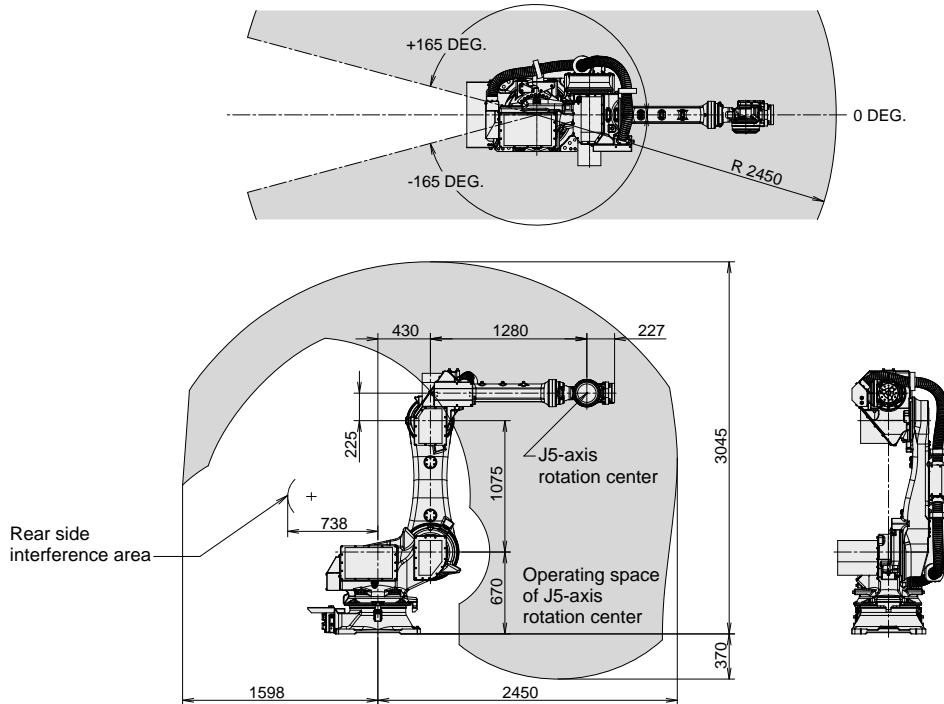

## Specifications

Model		R-2000iC/210WE	
Type		Articulated Type	
Controlled axes		6 axes (J1, J2, J3, J4, J5, J6)	
Reach		2450 mm	
Installation		Floor	
Motion range (Maximum speed) Note 1)	J1 axis rotation	330°( 95°/s)	5.76 rad (1.66 rad/s)
	J2 axis rotation	141°( 85°/s)	2.46 rad (1.48 rad/s)
	J3 axis rotation	318°( 95°/s)	5.55 rad (1.66 rad/s)
	J4 axis wrist rotation	720°(120°/s)	12.57 rad (2.09 rad/s)
	J5 axis wrist swing	250°(120°/s)	4.36 rad (2.09 rad/s)
	J6 axis wrist rotation	720°(190°/s)	12.57 rad (3.32 rad/s)
Max. load capacity at wrist		210 kg	
Max. load capacity at J2 base		550 kg	
Max. load capacity on J3 arm		-	
Max. load capacity on J3 casing		10 kg	
Allowable load moment at wrist	J4 axis	1333 N·m	136 kgf·m
	J5 axis	1333 N·m	136 kgf·m
	J6 axis	706 N·m	72 kgf·m
Allowable load inertia at wrist	J4 axis	141.1 kg·m <sup>2</sup>	1440 kgf·cm·s <sup>2</sup>
	J5 axis	141.1 kg·m <sup>2</sup>	1440 kgf·cm·s <sup>2</sup>
	J6 axis	78.4 kg·m <sup>2</sup>	800 kgf·cm·s <sup>2</sup>
Drive method		Electric servo drive by AC servo motor	
Repeatability Note 2)		± 0.1 mm	
Mass Note 3)		1180 kg	
Installation environment Note 4)		Ambient temperature : 0 to 55°C(Robot), 0 to 45°C(Controller) Washing solution temperature : Up to 60°C Vibration acceleration : 4.9 m/s <sup>2</sup> (0.5G) or less	

Note 1) During short distance motions, the axis speed may not reach the maximum value stated.

Note 2) Compliant with ISO 9283.

Note 3) Without controller.

Note 4) Air purge is required.

# FANUC CORPORATION

Headquarters Oshino-mura, Yamanashi 401-0597, Japan

Phone: 81-555-84-5555 Fax: 81-555-84-5512 <https://www.fanuc.co.jp>

●Overseas Affiliated Companies  
 FANUC America Corporation  
 FANUC Europe Corporation, S.A.  
 SHANGHAI-FANUC Robotics CO., LTD.  
 KOREA FANUC CORPORATION  
 TAIWAN FANUC CORPORATION  
 FANUC INDIA PRIVATE LIMITED  
 FANUC SINGAPORE PTE. LTD.  
 FANUC THAI LIMITED  
 FANUC MECHATRONICS (MALAYSIA) SDN. BHD.  
 PT. FANUC INDONESIA  
 FANUC OCEANIA PTY. LIMITED  
 FANUC SOUTH AFRICA (PROPRIETARY) LIMITED

3900 West Hamlin Road, Rochester Hills, MI 48309-3253, U.S.A.  
 7, rue Benedikt Zender, L-6468 Echternach, Grand-Duché de Luxembourg  
 No. 1500 Fuliang Road, Baoshan Area, Shanghai, China  
 101, Wanam-ro(st), Seongsan-gu, Changwon-si, Gyeongsangnam-do, 642-290 Republic of Korea  
 No.10, 16th Road, Taichung Industrial Park, Taichung, Taiwan  
 41-A, Electronics City, Bangalore, 560 100, India  
 No.1 Teban Gardens Crescent, Singapore 608919, Singapore  
 1301 Pattanakarn Road, Kwaeng Suanluang, Khet Suanluang, Bangkok 10250 Thailand  
 No.32, Jalan Pengacara U1/48, Temasya Industrial Park, Section U1, Glenmarie,  
 40150 Shah Alam, Selangor Darul Ehsan, Malaysia  
 J.L. Boulevard Bukit Gading Raya Blok R, Jakarta 14240 Indonesia  
 10 Healey Circuit, Huntingwood, NSW 2148, Australia  
 17 Loper Ave. Aeroport Industrial Ests. Spartan Ext.2 P.O.Box 219, Isando 1600, Republic of South Africa

Phone: 1-248-377-7000 Fax: 1-855-774-7051  
 Phone: 352-727777-1 Fax: 352-727777-403  
 Phone: 86-21-5032-7700 Fax: 86-21-5032-7711  
 Phone: 82-55-278-1200 Fax: 82-55-284-9826  
 Phone: 886-4-2359-0522 Fax: 886-4-2359-0771  
 Phone: 91-80-2852-0057 Fax: 91-80-2852-0051  
 Phone: 65-6567-8566 Fax: 65-6566-5937  
 Phone: 66-2-714-6111 Fax: 66-2-714-6120  
 Phone: 60-3-7628-0110 Fax: 60-3-7628-0220  
 Phone: 62-21-4584-7285 Fax: 62-21-4584-7288  
 Phone: 61-2-8822-4600 Fax: 61-2-8822-4666  
 Phone: 27-11-392-3610 Fax: 27-11-392-3615

- All specifications are subject to change without notice.
- No part of this catalog may be reproduced in any form.
- The products in this catalog are controlled based on Japan's "Foreign Exchange and Foreign Trade Law". The export from Japan may be subject to an export license by the government of Japan. Further, re-export to another country may be subject to the license of the government of the country from where the product is re-exported. Furthermore, the product may also be controlled by re-export regulations of the United States government. Should you wish to export or re-export these products, please contact FANUC for advice.

© FANUC CORPORATION, 2013

RR-2000iC(E)-08, 2020.4, Printed in Japan